



PH-Series

Receiving and Rigging Manual

Installer

Please take the time to read and understand these instructions prior to any installation. Installer must give a copy of this manual to the owner.

Owner

Keep this manual in a safe place in order to provide your service technician with necessary information.

Phoenix Air Systems

170 Landmark Drive, Suite B
Owatonna, Minnesota 55060
Telephone: +1.507.451.3524
Fax: +1.507.451.9185

www.phoenixairsystems.com

SECTION 1: RECEIVING AND RIGGING

1.1 Receiving

Depending on air handler size, it is shipped as one assembly or in multiple sections. Air handler was inspected and operated prior to shipment.

1.2 Inspection

Check all items against bill of lading to ensure all cartons and crates have been delivered. Carefully check all components for damage. Immediately note any visible shortage or damage on bill of lading and submit a claim to the carrier. If additional damage is found after further inspection, immediately submit another claim to the carrier. These steps must be taken to preserve your right to reimbursement from the carrier.

Any small accessories which do not come attached to air handler (i.e. filters, remote panel or disconnect) will be found inside air handler. Larger accessories (i.e. diffusers, hoods) may either ship with air handler or separately on another truck. Check bill of lading for information.

1.2.1 Inspection Checklist

Check items below for damage. If further damage is found *see Page 1, Section 1.2*.

1. Inspect all access doors to confirm latches and hinges are not damaged.
2. Check all coil connections to confirm they are straight and undamaged.
3. Inspect coils for damage to fin surface or coil connections.
4. Refrigerant coils on evaporators are shipped from factory with a low pressure nitrogen charge. Quickly open valve on coil headers to hear or feel nitrogen escaping. Close valve after verifying coil charge. Maintain charge until just before connecting refrigerant piping to air handler.

If coil does not appear to be charged, it may have been damaged during shipment. Pressure test coil with dry nitrogen gas to ensure coil does not have a leak. Before installation, notify factory of coils that have lost factory nitrogen charge.

5. Check control enclosures, electrical enclosures and other items attached to air handler exterior and confirm they are not damaged.

6. Inspect interior of each section for any internal damage as soon as possible after delivery.
7. Check internally mounted controls (if ordered); locate all sensors and actuators and inspect for damage.
8. Check to make sure lifting lugs are intact, undamaged and secured to air handler.

1.3 Resolving Shipping Damage

PH-Series air handlers ship FOB factory. If damage has occurred to air handler sections during shipment, the following instructions should be followed:

1. Make specific notation describing damage on freight bill.
2. Take pictures of damage.
3. Immediately report all claims of shipping damage to delivering carrier.
4. Keep damaged material in same condition as it was received. It is receiver's responsibility to provide reasonable evidence concealed damage was not incurred after delivery.
5. Notify factory of damage and arrange for repair. Do not attempt to repair air handler without consulting Phoenix Air Systems or a PHOENIX AIR SYSTEMS™ independent distributor. Phoenix Air Systems is not responsible for shipping damage.

1.4 Storage Considerations

If air handler must be temporarily stored or placed on the ground (i.e. job site is not ready for installation of air handler), it should be set on 4" x 4" (10 cm x 10 cm) pieces of timber on the ground in a safe area to protect from damage. Cover air handler to protect from environment.

Keep equipment in original shipping arrangement for protection and ease of handling. Place all boxes shipped inside air handler in a dry location until required for installation.

If air handler is shipped in sections, plywood shipping end covers should be kept in place. Remove plywood end covers prior to assembling air handler.

Warranty does not cover damages to air handler or components due to negligence during storage.

1.4.1 Long Term Storage

For longer periods of storage, allow enough clearance around air handler to perform periodic inspection and maintenance.

Check inside all access doors for evidence of animal or insect presence or other foreign matter. Clean or remove as required.

Loosen belt tension on drive belts. Every two weeks, rotate fan and motor shaft thirty revolutions by hand. Check for free rotation. Every six months, check fan shaft bearing and grease lines.

Check motor lubrication; remove and clean grease plugs and check for presence of moisture in grease. If moisture is present, remove motor and send it to an authorized repair shop for bearing inspection/replacement. If moisture is not present, refer to motor manufacturer's lubrication recommendation for proper lubrication.

1.5 Safety Labels and Their Placement

Product safety signs or labels should be replaced by product user when they are no longer legible. Avoid placing labels on areas with extreme heat, cold, corrosive chemicals or other elements. To order additional labels, please contact Phoenix Air Systems or your PHOENIX AIR SYSTEMS™ independent distributor.

1.6 California Proposition 65

In accordance with California Proposition 65 requirements, a warning label must be placed in a highly visible location on the equipment (i.e., near equipment's serial plate). See *Page 2, Table 1* for label part numbers.

1.7 Product Labels

Table 1: Product Labels

Part Number	Description
PA13592730	Serial plate, main control cabinet
PA13592731	Serial plate, VFD cabinet
PA13592732	Serial plate, gas train cabinet
PA13592733	Serial plate, smoke detector cabinet
PA13592734	Serial plate, remote panel
14302372	Burner access
143023-01	Check tightness of bearings
20930011	Logo label 24" x 8"
20930012	Logo label 10" x 3.3"
PA20930016	Drain must be trapped
PA20930025	Filter access
PA20930033	Blower, motor and drives' access
91010100	Manual location (for shipping only)
91010427	Vent to outdoors
91010431	Improper installation
91070001	Shock hazard
91070002	Severe injury hazard
91070004	Fire hazard
91070005	Falling hazard
91070006	Burn hazard
91070007	Crush hazard
91070016	Prop 65
91070032	Serial plate, shock hazard
91070033	Serial plate, shock hazard
91070034	UV light

SECTION 2: LIFTING AN AIR HANDLER

! WARNING**Crush Hazard**

Use proper lifting equipment and practices.

Failure to follow these instructions can result in death, injury or property damage.

! CAUTION

Only use crane to move air handler.

Do not push or pull air handler on ground.

Failure to follow these instructions can result in equipment damage.

! WARNING**Falling Hazard**

Use proper safety equipment and practices to avoid falling.

Failure to follow these instructions can result in death, injury or property damage.

Depending on air handler size, it is shipped as one assembly or in multiple sections. If air handler is shipped in multiple sections, lift each piece separately.

2.1 Preparing to Lift Air Handler:

Prior to lifting air handler, perform the following steps.

1. Remove all banding or blockers attached to air handler and ensure air handler is no longer bound to truck.
2. Remove all packaging materials if applicable. See Page 3, Figure 1. Remove the screws that attach the plywood to the packaging clips and discard. Remove the screws or dis-engage the hardware that attach the packaging clips to the equipment, discard the screws and clips. Fail-

ure to remove the screws and clips will result in misalignment in the assembly process.

3. Remove all accessories or packages that were shipped with air handler, inside air handler or inside control enclosure.

Note: Equipment mechanical and electrical drawings are located inside the main control panel, along with accessory drawings.

4. Verify lifting lugs are intact, undamaged and secured to air handler.

FIGURE 1: Removing Shipping Packaging

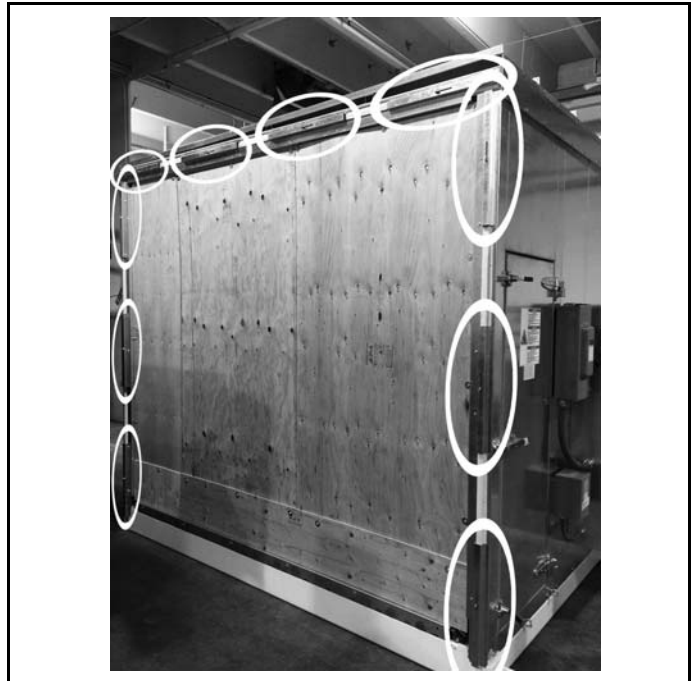

5. Prepare installation or storage location to accept air handler (i.e. roof curb, structural steel, platform or 4" x 4" (10 cm x 10 cm) timbers for storage placement). See Page 5, Section 3.
6. Verify lifting equipment can handle air handler's weight and required reach. Refer to mechanical submittal drawing.
7. Estimate center of gravity and test lift air handler to determine balance and stability. Air handler may be unbalanced or top heavy depending on its accessories, so it is imperative to lift air handler properly. Due to placement of internal components, air handler's weight may be unevenly distributed with more weight at coil and blower sections.
8. Air handler must be kept level and upright during lift to prevent tipping, twisting or falling. Do not move or lift air handler tilted, upside down or on its side.

9. Before lifting air handler, make sure there are no loose items on air handler.
10. Never lift air handler in windy conditions or above personnel.

2.2 Lifting Air Handler

Lift air handler into place installing appropriate hardware (supplied by others) into all lifting lugs. Some air handlers have more than four lifting lugs. Use all lifting lugs to lift air handler. Use spreader bars to ensure lifting cables or chains clear sides of air handler and any protruding items such as coil connections, control panels and door handles. See *Page 4, Figure 2*.

If air handler is shipped in multiple sections, lift each section separately and assemble, once all sections are securely placed on platform or curb.

FIGURE 2: Lifting Air Handler

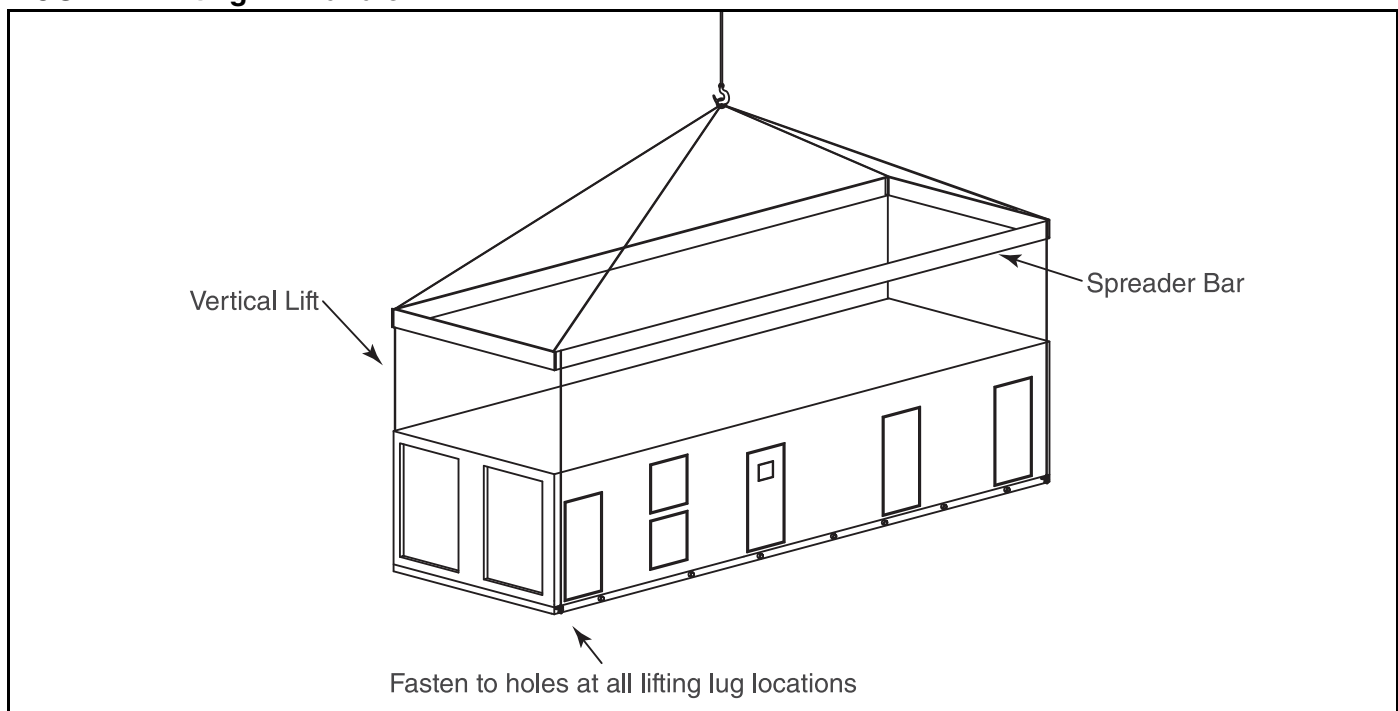

SECTION 3: PREPARING INSTALLATION SITE

should provide final field piping and ducting plans and specifications.

3.1 Installation Site Considerations

When preparing air handler site, consider the following:

1. Ensure that site can support total weight of air handler. *See Page 7, Section 5.*
2. Air handlers may require railings or other safety devices for personnel safety. Consult OSHA and local code requirements.
3. Confirm foundation of mounting platform or curb is large enough to include air handler dimension. Refer to submittals for specific dimensions.
4. Determine a suitable location, which will minimize effect of exhaust air recirculation as recirculated exhaust air can significantly derate air handler's capacity and hinder proper performance/operation.
5. Provide sufficient space to allow adequate air flow to air handler's fresh air inlet and exhaust louvers/fans.
6. Provide adequate height for condensate drain requirements. Insufficient height may inhibit condensate drainage and result in flooding air handler.
7. Provide adequate lighting for maintenance personnel to access.
8. Provide permanent power outlets in close proximity of air handler for installation and maintenance.
9. Ensure field piping and ductwork are strongly supported and properly anchored. Do not use field piping or ductwork to support air handler. Wind loading, temperature variation, etc. must be considered to allow for movement between the system, adjoining building, ducting and field piping. A qualified system design engineer

SECTION 4: CRITICAL CONSIDERATIONS**! WARNING****Fire Hazard**

Keep all flammable objects, liquids and vapors the minimum required clearances to combustibles away from equipment.

Some objects will catch fire or explode when placed close to equipment.

Failure to follow these instructions can result in death, injury or property damage.

4.1 Required Clearances

Check the clearances on each air handler being installed to make sure the product is suitable for your application and the clearances are maintained.

Minimum clearances for all models are as follows:

- 18" (45.7 cm) Above the top of the equipment
- 18" (45.7 cm) Along the sides of the equipment
- 18" (45.7 cm) From the base rail of the equipment (when suspended) or installed on combustible floor.

4.2 Required Clearances to Combustibles

Clearances are the required distances that combustible objects must be away from the air handler to prevent fire hazards. Combustibles are materials that may catch on fire and include common items such as wood, paper, rubber, fabric, etc.

Maintain clearances to combustibles at all times for safety.

Check the clearances on each air handler being installed to make sure the product is suitable for your application and the clearances are maintained.

For PH model units equipped with a direct-fired burner section refer to the clearances listed in *Section 4.1*.

For PH model units equipped with an Indirect-Fired burner section see *Page 6, Section* and the following.

Minimum clearances for all models are as follows:

- 36" (91.4 cm) Around the flue pipe
- 36" (91.4 cm) Around the sight port

The stated clearances to combustibles represent a surface temperature of 90 °F (32 °C) above room temperature. Building materials with a low heat tolerance (i.e. plastics, vinyl siding, canvas, tri-ply, etc.) may be subject to degradation at lower temperatures. It is the installer's responsibility to assure that adjacent materials are protected from degradation. Maintain clearances from heat sensitive material, equipment and workstations.

4.3 Required Clearances for Accessibility

Minimum clearance for access is 48" (122 cm). Minimum clearance for accessibility applies to the access point area of control enclosure(s), access door(s). If the unit is equipped with an heat exchanger, the minimum clearance for accessibility when replacing it is equal to the width of the unit.

Inlet hood opening shall not be installed with inlet opening facing into the prevailing wind direction in order to help prevent the possibility of moisture entrainment.

4.4 Clearances for Outside Air Intake Hoods/ Louvers

Outside air intake hoods/louvers should not be in close proximity of building or process exhaust stack(s)/opening(s), chimney(s) or combustion exhaust of other equipment. The air handler shall be oriented so building or process exhaust is not ingested into the air handler's outside air intake. Refer to the International Building Code and/or the International Mechanical Code and NFPA 54 National Fuel Gas Code for guidelines.

SECTION 5: AIR HANDLER SUPPORT

⚠ WARNING			
			
Crush Hazard Use proper lifting equipment and practices.	Falling Hazard Use proper safety equipment and practices to avoid falling.	Severe Injury Hazard Use proper lifting practices and equipment. Equipment and accessories are heavy.	Cut/Pinch Hazard Wear protective gear during installation, operation and service. Edges are sharp.
Failure to follow these instructions can result in death, injury or property damage.			

PH-Series air handlers can be installed on a roof (structural steel platform or full perimeter roof curb) or indoor (building's structural steel frame). The site must be able to support entire weight of air handler, support structures and accessories. See submittal drawings for air handler and accessory weights.

- Install structural steel or roof curb before hoisting air handler to roof.
- Complete all electrical, ductwork and piping connections only after air handler is mounted.
- Ensure support structure is capable of supporting total system operating weight plus a significant safety margin as determined by a qualified structural engineer. Support footing and anchoring requirements will vary with live loads, seismic and wind loading.

IMPORTANT: For proper operation, air handler must be installed level (zero tolerance) in both horizontal axes. Failure to level air handler properly may result in moisture management problems such as standing water inside air handler.

Standing water and wet surfaces inside air handler can result in microbial growth that may cause decreased final filter life, unpleasant odors and possible product quality problems.

5.1 Structural Steel Support Installation

Structural steel support is the most common support structure for most PH-Series applications. Support structure should be designed by a qualified structural engineer and must be designed sufficiently to support entire air handler weight along with any accessories mounted to air handler. At a minimum,

support should provide a full perimeter support and at each section split or a center support running lengthwise to air handler.

FIGURE 3: Structural Steel Support

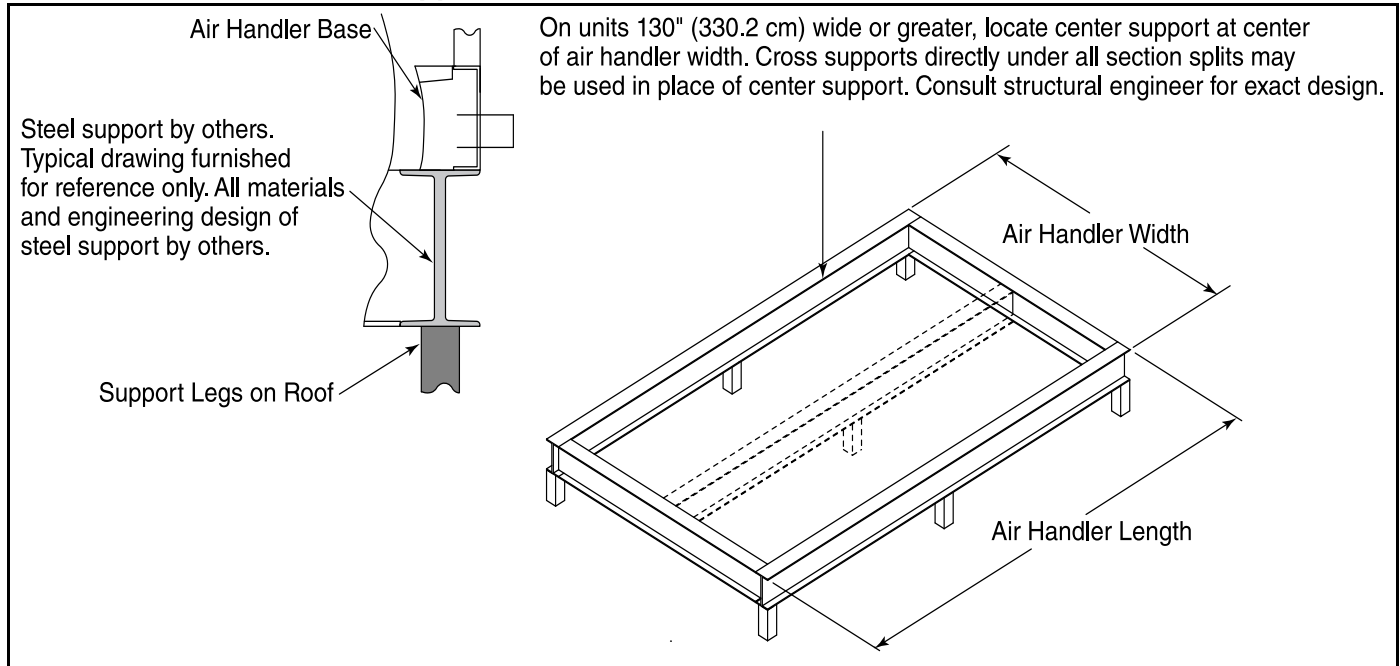

5.2 Roof Curb Support

Roof curbs are available for all equipment that are roof mounted. Roof curbs are shipped knocked down and require field assembly.

Note: Before installation, verify that you have the correct roof curb and that all required components are present. If any are missing, contact your Phoenix Air Systems™ independent representative.

5.2.1 Roof Curb Assembly and Installation

Assemble roof curb according to the assembly drawing supplied with the curb. Supplied hardware must be torqued to required specifications. Place the curb on the roof in the position in which it will be installed. Check that the diagonal measurements are within 1/8" (3 mm) of each other. To ensure a weatherproof seal between the air handler and the curb, the curb must be level with no twist from end to end. Shim level as required and secure curb to roof deck using best building practices. The curb is self-flashing. Install roofing material as required.

Note: Check the installation location to ensure proper clearances to combustibles and clearance for

access. See Page 6, Section 4.2.

5.2.2 Air Handler Mounting to Roof Curb Support

After the curb has been installed, the air handler may be placed on the curb. There must be a 1/4" (0.67cm) neoprene closed cell, adhesive-back gasket (supplied by others) between the top of the curb and the base surface of the air handler to prevent moisture from leaking into the building (ie. from driving rains or melting snow). See Page 10, Figure 5. The installer is responsible for tying the air handler to the curb per all applicable codes.

IMPORTANT

Roof curbs cannot be used on applications where room design temperature is below 60 °F (16 °C) without special considerations. For these applications, air handler must be mounted on structural steel or provisions must be made to ventilate/drain inside of curb. Roof curb height varies. See submittal drawings. Consult factory for more information.

FIGURE 4: Roof Curb Support

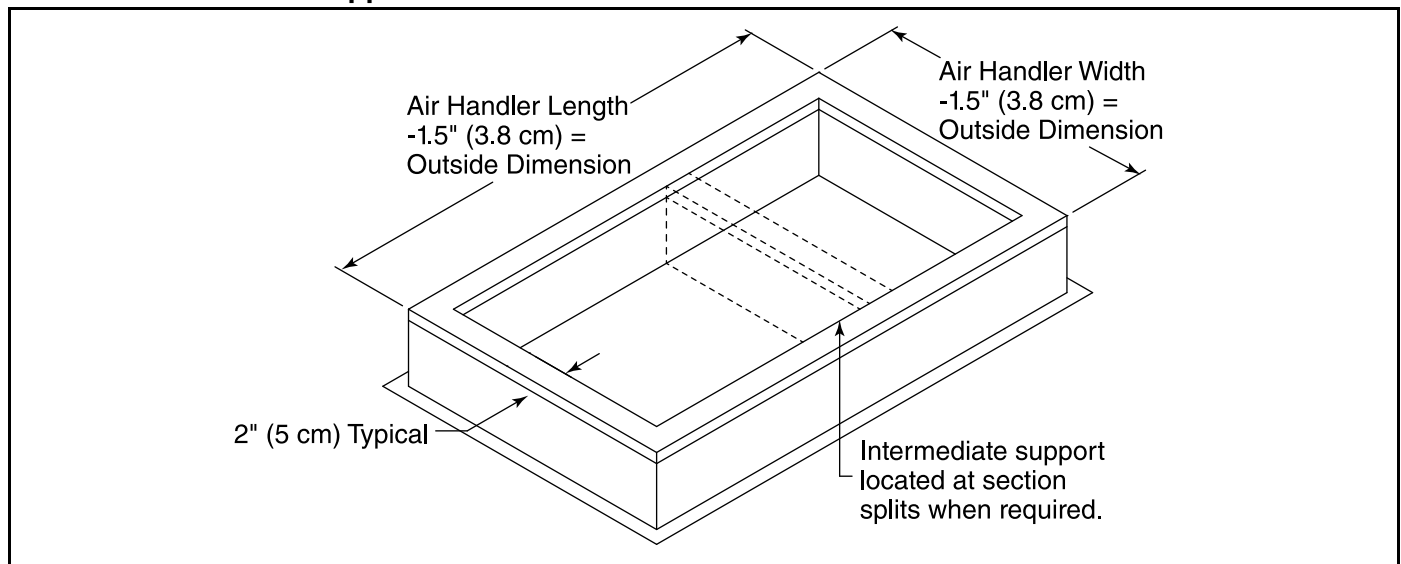
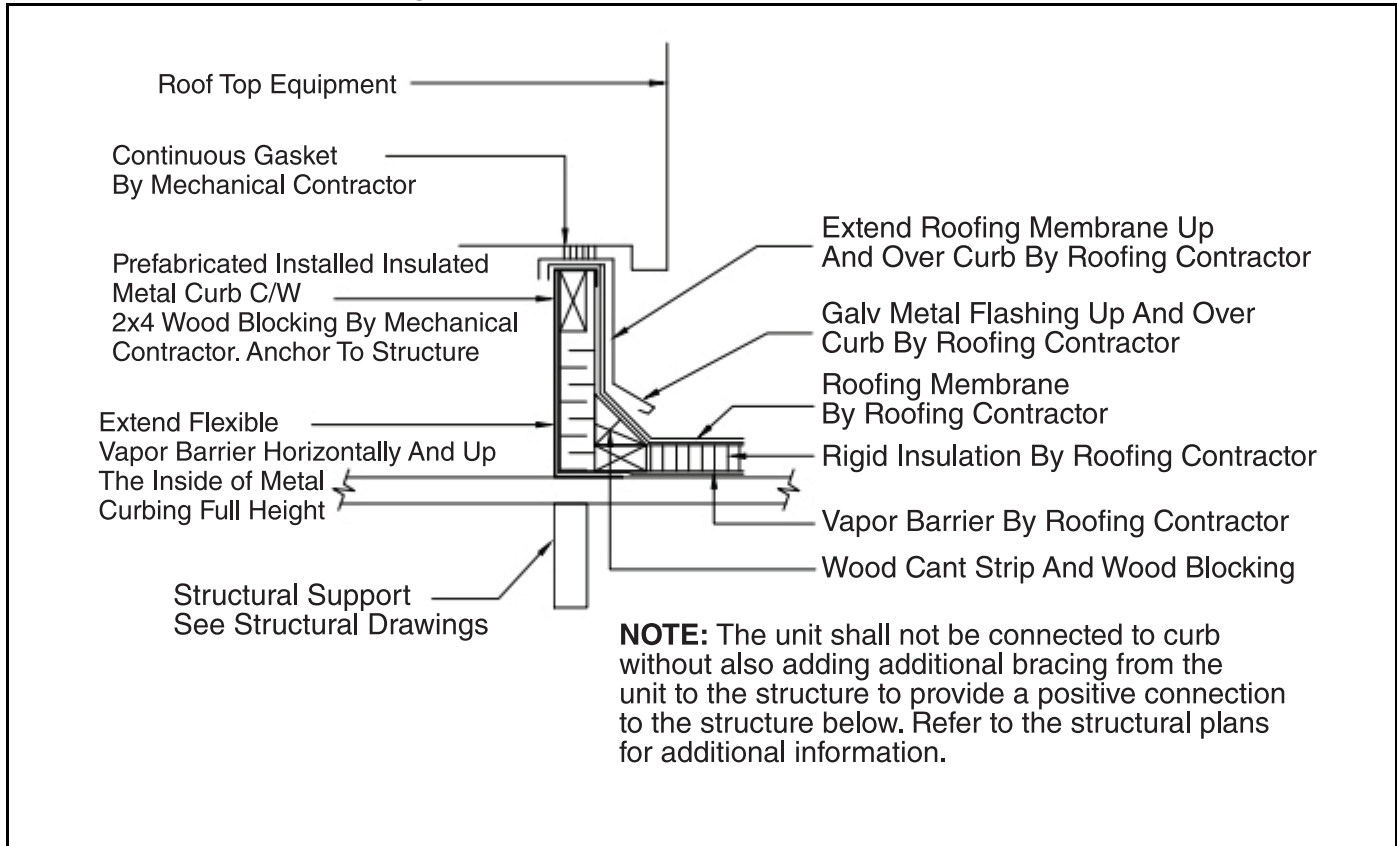

FIGURE 5: Roof Curb Flashing Detail



5.3 Indoor Installation

For this method, a structural support stand (by others) is engineered and constructed for mounting inside building. Support structure should be designed by a qualified structural engineer to sufficiently support entire air handler weight along with any accessories mounted to air handler. At a minimum, support should provide a full perimeter support and at each section split or a center support running lengthwise to air handler.

